

4

3

2

1

D

D

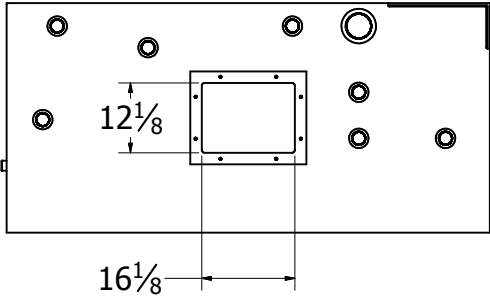

Inner Tank Showing Cut Out Detail

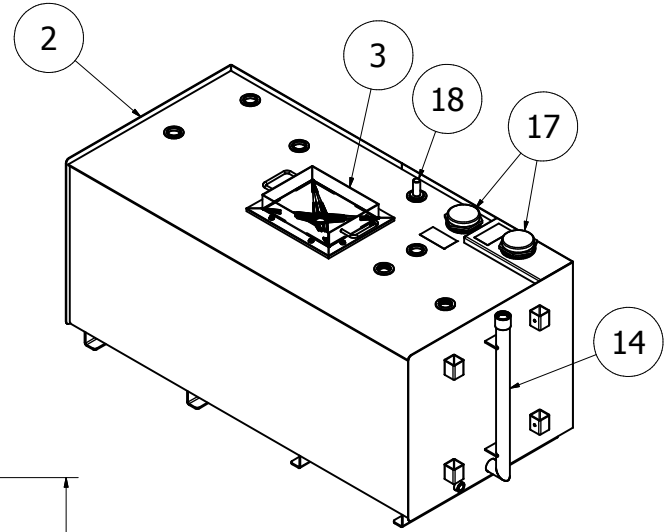

C

C

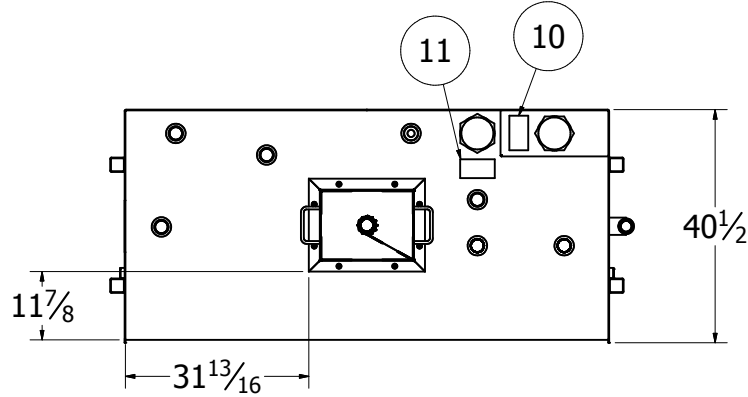

B

B

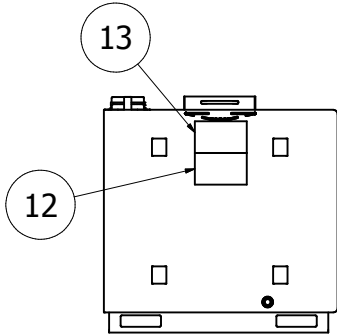

A

A

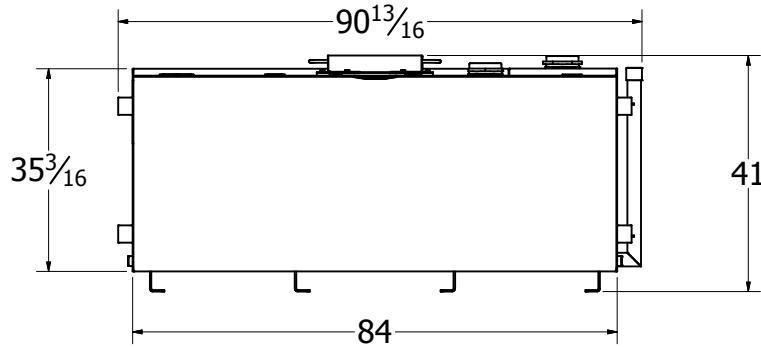

Decimal Conv	
1/16 = 0.0625	
1/8 = 0.125	
3/16 = 0.1875	
1/4 = 0.25	
5/16 = 0.3125	
3/8 = 0.375	
7/16 = 0.4375	
1/2 = 0.50	
9/16 = 0.5625	
5/8 = 0.625	
11/16 = 0.6875	
3/4 = 0.75	
13/16 = 0.8125	
7/8 = 0.875	
15/16 = 0.9375	

A

A

BREAK EDGES .01 ± .005 UNLESS OTHERWISE SPECIFIED MUST BE FREE OF BURRS WHICH MAY BE DETRIMENTAL TO SATISFACTORY ASSEMBLY, SAFE HANDLING, OR FUNCTION.	
SURFACE SPECS.	AS NOTED
HEAT TREAT SPECS.	AS NOTED
GRIND SPECS.	AS NOTED

MATERIAL DESCRIPTION: Powder Coat: Semi-Gloss Black
<small>*This drawing is the property of Steinhaus Brothers Incorporated / SBI mfg and is loaned to the recipient for his confidential use only. In consideration of the loan of this drawing, the recipient promises and agrees that it shall not be used in any way detrimental to the interest of Steinhaus Brothers Incorporated / SBI mfg. That it shall be returned upon request, and that it shall not be reproduced, copied, loaned, or otherwise disposed of, directly or indirectly without the express written consent of Steinhaus Brothers Incorporated / SBI mfg.*</small>

FINISH UNLESS OTHERWISE NOTED: STOCK		
MACHINGING (in)	MACHINGING (in)	FABRICATION (in)
0 - 5 ± 0.005	ANGLES ± 0.25°	0 - 5 ± 0.08
5 - 10 ± 0.02		5 - 100 ± 0.1
10 - 50 ± 0.04		over 100 ± 0.2
over 50 ± 0.06		

SBI MANUFACTURING 47061 Phillip street Sioux Falls, SD 57108 (605)-368-2340		
PART NO./DESCRIPTION ABR500DW		
SUBASSEMBLY NO./DESCRIPTION 500 Gallon Double Wall Tank		
DATE 5/8/2019	DRAWN Trent S.	CHECKED
PRINT NO.	ABR500DW	SCALE: 1/1

4

3

4

2

1